

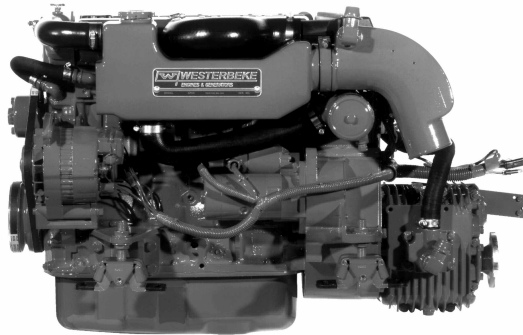

Higher torque and a low 2600 rpm...



55D Four Diesel Engine

Quiet and Compact

Designed to fit in the smallest engine compartments, the 55D Four offers 4-cylinder, 4-cycle smoothness in a lightweight, compact engine. A tuned air intake silencer and 4-point vibration mounts diminish sound and vibration for a smooth and quiet ride.

Powerful and Reliable

The naturally aspirated 2.18 liter design of the 55D Four provides instant power as well as simplicity and reliability. The 55D Four is rated at a low 2600-rpm for longer engine life and delivers dependable power without sacrificing smooth, quiet operation.

Easy Operation and Maintenance

In order to minimize engine maintenance, a fresh water cooling system and self-bleeding fuel system are designed into the 55D Four. For ease of maintenance, the raw water pump is conveniently located on the service side of the engine. Incorporated into the design of the 55D Four is a standard, positive flow, hot water heater connection in the thermostat bypass circuit located on the front of the engine for easy access.

Many Optional Accessories

Many optional accessories are available including large single and dual output battery charging alternators and refrigeration compressor mounts. Factory engineered and factory installed, an owner or builder benefits from these complete and properly designed systems.

The Name You Can Trust

The presence of Westerbeke in over 65 countries around the world provides customers with easy access to parts, service and technical support worldwide. Established in 1937, Westerbeke is committed to providing its customers with quality products and unequalled after sales support.

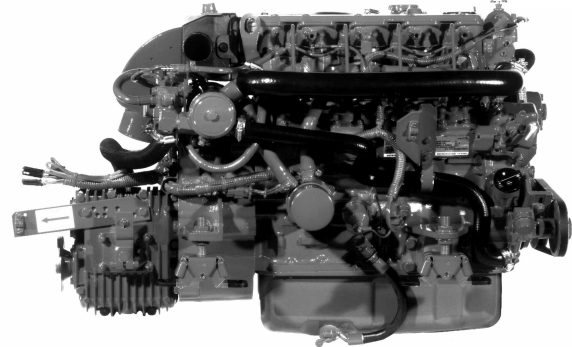

55D Four Diesel Engine

Standard Features

- Engine pre-wired to plug-in connector
- Circuit breaker protected electrical system
- Electric stop
- Self-bleeding fuel system
- Belt-driven, raw water pump
- Fresh water cooled engine
- Transmission oil cooler
- Engine oil cooler
- 12 volt, 50 amp alternator
- Domestic hot water connection
- Coolant recovery tank
- Throttle, stop, and shift control brackets
- Low oil pressure and high water temperature alarms
- Oversized marine transmission with 1.88:1 reduction
- Glow plug cold starting aid
- Engine matched four-point, fail-safe, adjustable mounts
- Lube oil drain hose
- Tuned air intake silencer with filter
- Operators' manual and parts list
- Large list of factory engineered options



Optional Admiral Panel

Admiral Panel Dimensions

Length	9.75" (247.7 mm)
Depth	4.0" (101.6 mm)
Height	6.0" (152.4 mm)

Maximum Output at Crankshaft = 48 HP (35.9 kW) at 2600 rpm

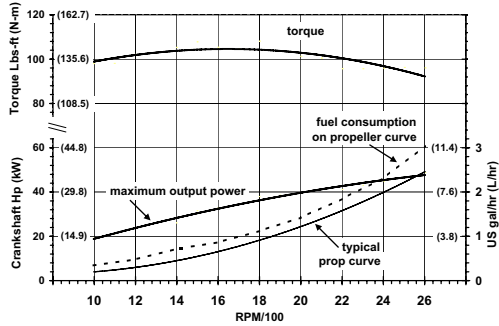

Westerbeke recommends a propeller that will allow the engine to turn 2600 rpm underway at full throttle. Output is according to ISO 8665/3046. Fuel density 0.840 kg/L at 15 °C. Output includes +/- 5% tolerance.

Specification

Number of cylinders	4 Cylinder vertical in-line
Cycles	4 Cycle
Displacement	133.0 cu. in. (2.18 liter)
Bore and stroke	3.35" x 3.78" (85 mm x 96 mm)
Compression ratio	21.5:1
Maximum angle of installation	Not to exceed 14°
Maximum angle of rotation	Not to exceed 30° for 30 min.
Crankshaft, direction of rotation	Counterclockwise as viewed from flywheel end
Propeller shaft, direction of rotation	Right hand—std. trans.
Dry weight	448 lbs (203.2 kilos)
Combustion system	Swirl type
Aspiration	Naturally aspirated
Lubrication system	Trochoid type pump
Cooling system	7.25 quarts (6.86 liters)
Starting aid	12 volt sheathed type glow plug
Engine stop	Electric
Fuel injection pump	Bosch type (individual)
Governor	Centrifugal type
Injectors	Throttle type
Fuel filter	Primary
Lube oil filter	Full flow, spin-on element
Lubricant capacity	8.9 quarts (8.4 liters)
Lube oil cooler	Fresh water cooled
Fuel transfer pump	Electrical
Fuel supply and return piping	1/4" ID (6.35 mm) minimum 3/8" ID (9.53 mm) maximum
Starting motor	12 volt, solenoid actuated
Battery charging alternator	50 ampere (12 volts)
Cold cranking amps	284 amps at 77° F
Electrical system	12 volts DC, negative ground

Construction—Engine Components

Cylinder head	Cast Iron
Cylinder block	Cast Iron
Crankshaft	Ductile cast iron, five main bearings
Valves	Overhead valves
Fuel System	Self bleeding
Intake system	Tuned intake silencer with air filter for maximum noise reduction
Cooling system	Fresh water-cooled with tube and shell type heat exchanger
Exhaust manifold	Cast aluminum, fresh water-cooled with built-in expansion tank

Standard Equipment

Standard gear ratio	1.88:1
Mounting centers	16.0" & 18.5"
Flexible mounts	Engine matched adjustable fail safe neoprene type
Electric stop	
Domestic hot water connection	
Coolant recovery tank	
Battery charging alternator	50 amp, 12 volt
Starting aid	
Control brackets	Throttle and shift
Prewired Engine	
Belt-driven raw water pump	
Lube oil drain hose	
Transmission oil cooler	
Engine oil cooler	
Circuit breaker protected electrical system	
Oil fill	Top and service side
Operator's Manual and Parts List	

Optional Equipment

Captain panel with alarm (tachometer with lights)	
Admiral panel with alarms (tachometer with gauges)	
Dual station senders	
Other gear ratios	Consult local Distributor
Hydraulic transmissions	Consult local Distributor
Remote expansion tank	
Provision for refrigeration compressor	
Muffler and fittings	
"A" and "B" on board spare parts kits	
Alternator, 100, 160, 190 amp single output	
Anti-siphon valve for overboard cooling discharge water	
Technical Manual	
Exhaust connection (water injected 70° elbow)	
Propeller shaft couplings (rigid/flexible)—available standard sizes	

Dimensions Inches (millimeters)

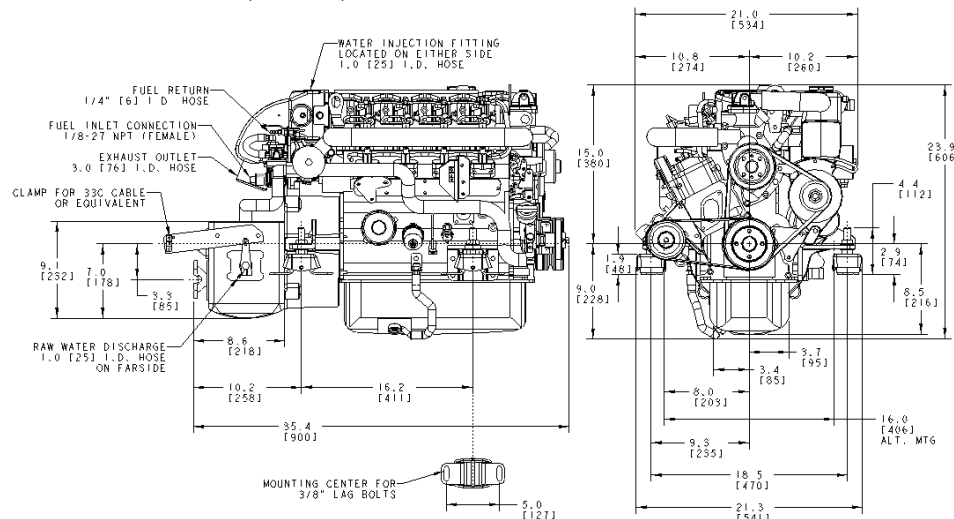

Authorized Dealer