



MARINE DIESEL ENGINES

HPEP 205



SCHEDA TECNICA | TECHNICAL DETAILS

Configurazione <i>Configuration</i>	4 tempi, doppio asse a camme, 16 V <i>4-stroke cycle, twin camshaft, 16 V</i>
Potenza max all'albero <i>Maximum output at crankshaft</i>	147 kW/200 hp a 4100 giri/min. <i>147 kW/200 hp at 4100 rpm</i>
Potenza max all'elica <i>Maximum output at propeller</i>	142 kW/193 hp a 4100 rpm <i>142 kW/193 hp at 4100 rpm</i>
Coppia max <i>Maximum torque</i>	370 Nm a 2600 giri/min. <i>370 Nm at 2600 rpm</i>
Potenza max all'albero con Power Rating classe B <i>Maximum output at crankshaft with Power Rating B-class</i>	125 kW/170 hp@ 4100 giri/min
Potenza max all'albero con Power Rating classe C <i>Maximum output at crankshaft with Power Rating C-class</i>	103 kW/140 hp@ 4100 giri/min
Cilindrata totale <i>Displacement</i>	1.956 c.c.
Alesaggio per corsa <i>Bore x stroke</i>	83 x 90,4 mm
Cilindri <i>Cylinders</i>	4, in linea <i>4, in line</i>
Sistema di iniezione <i>Combustion system</i>	Iniezione diretta Common rail <i>Direct injection Common rail</i>
Aspirazione <i>Aspiration</i>	Sovralimentato con turbocompressore a geometria variabile <i>Supercharged with variable geometry turbo</i>
Sistema di avviamento <i>Starting system</i>	Motorino di avviamento elettrico 12 V - 2,1 kW <i>Electric starting 12 V - 2,1 kW</i>
Alternatore <i>Alternator</i>	12 V - 140 A
Sistema di raffreddamento <i>Cooling system</i>	Doppio circuito con scambiatore di calore <i>Double water cooling system with heat exchanger</i>
Sistema di lubrificazione <i>Lubrication system</i>	Forzata con pompa ad ingranaggi <i>Forced lubricating system with pump</i>
Max inclinazione di montaggio <i>Max. mounting inclination</i>	14°
Peso a secco senza trasmissione <i>Dry weight without sterndrive</i>	290 kg
Supporti motore <i>Engine mounting</i>	Supporti elastici anti-vibranti <i>Rubber type anti-vibration mounting</i>
Certificazione <i>Environmental</i>	RCD 2003/44/CE ed EPA TIER 3 <i>RCD 2003/44/CE and EPA TIER 3</i>

POTENZE SECONDO ISO 8665, COMBUSTIBILE DIESEL EN 590, TOLLERANZA SULLA POTENZA 5%
POWER ACCORDING ISO 8665, TOLERANCE 5%, DIESEL FUEL ACCORDING EN 590

POTENZA | POWER

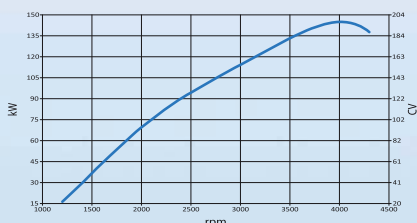

COPPIA | TORQUE Nm

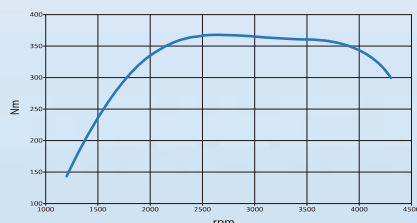

CONSUMO SPECIFICO | SPECIFIC FUEL CONSUMPTION

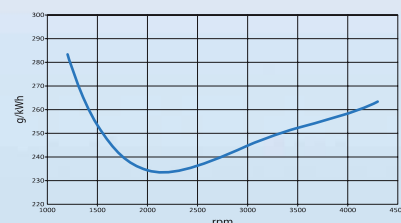



Authorized Dealer:
BAYSAN MARINE
 Tel. +90 212 485 17 14 (pbx)
 Info@baysanmarine.com

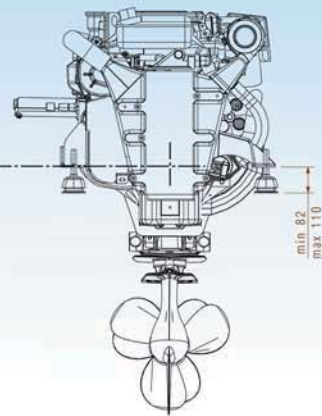
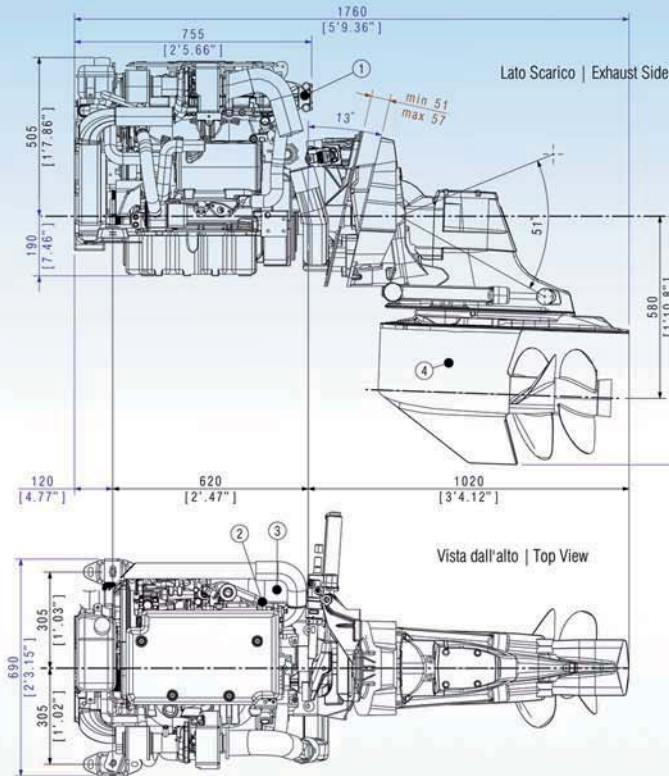

Ref. #	Description
1	Pompa acqua mare Raw water pump
2	Potenzimetro Potentiometer
3	Ingresso Carburante Fuel Inlet
4	Mercuriser Bravo III

FNM HPEP 205 Bravo X-3 | FNM HPE 205 Bravo X-3
 Diametro gomito di scarico 90 mm | Exhaust riser diameter 90 mm
 Diametro ingresso gasolio 8 mm | Fuel line inlet diameter 8 mm
 Diametro ingresso acqua mare 32 mm | Sea water line inlet diameter 32 mm

QUADRO STRUMENTAZIONE | INSTRUMENT PANEL

- Strumento CANBUS Contagiri (5 pollici) e quadro sciolto con spie allarme e blocco chiave | CANBUS Tachometer (5") and separated panel with alarm lights and key block
- Display multifunzione con visualizzazione di: Temperatura motore, Pressione olio, Tensione Batteria, Pressione Boost, Carburante, Angolo di Trim | Multifunction display with info about: Engine temperature, Oil pressure, Voltage, Boost Pressure, Fuel, Trim
- Strumenti aggiuntivi disponibili: Multifunzione (5 pollici), Velocità (5 pollici), Strumenti singoli (2 pollici) | Additional instruments available: Multifunction (5"), Speedometer (5") Single gauges (2")
- Standard CANBUS J1939 espandibile a NMEA2000 | CANBUS Standard J1939 upgradable to NMEA2000



ACCESSORI DOTAZIONI STANDARD | ACCESSORIES STANDARD PACKAGE

- Piede poppiero Bravo X-1 Rid. 1,65:1 oppure Bravo 2 Rid. 2:1 - Bravo 3 Rid. 2:1 | Bravo X-1 stern drive Red. 1,65:1 or Bravo 2 Rid. 2:1 - Bravo 3 Rid. 2:1
- Set di supporti anti-vibranti | Set of flexible mounts
- Alternatore 12 V - 140 A | Alternator 12 V - 140 A with built-in regulator
- Motorino avviamento 12 V - 2,1 kW | Starter motor 12 V - 2,1 kW
- Filtri olio e combustibile | Oil and fuel filters
- Collettore scarico refrigerato | Water-cooled exhaust manifold
- Pompa acqua mare in bronzo | Bronze seawater pump
- Servosterzo originale Mercuriser con pompa idroguida | Mercuriser Steering System with Hydraulic Pump
- Filtri Racor | Racor filters
- Condotto di scarico | Exhaust riser
- Quadro strumentazione con 8 mt. cablaggio | Instrument panel with 8 mt. cable
- Cover motore | Engine top cover

OPTIONAL | OPTIONAL

- Monoleva a cruscotto singola e doppia installazione | Dashboard single and double remote control
- Monoleva elettronica CAN singola e doppia installazione | CAN single and double remote control
- Elica acciaio per Bravo X-1 | "Mirage" stainless steel propeller for Bravo X-1
- Elica alluminio per Bravo 2 | Aluminium propeller for Bravo 2
- Eliche acciaio per Bravo 3 | Stainless propellers for Bravo 3
- Barra accoppiamento per bimotore | Multiple Sterndrive Steering Tie Bar Arrangement
- Quadro flybridge con 8 mt. cablaggio | Flybridge instrument panel with 8 mt. cable
- Kit tubazione per riscaldamento interno imbarcazione | Kit for boat internal heating
- Cablaggio ausiliario 2 mt. | 2 mt. auxiliary extension cable
- Barra allineamento motore | Alineament toll
- Puleggia anteriore a due gole libere ISO 4183 profilo A | 2-groove front pulley ISO 4183 type A
- Sistema di propulsione ibrido FNM HS | Hybrid propulsion system FNM HS
- Connessione NMEA2000 per GPS | GPS NMEA2000 standard connection



N° 1294605/05/S

N° EMS-224/S

N° TS/12946/05