



MARINE DIESEL ENGINES

HPE 110



SCHEDA TECNICA | TECHNICAL DETAILS

Configurazione <i>Configuration</i>	4 tempi ciclo diesel, DOHC 16 V con distribuzione a catena <i>4-stroke diesel, DOHC 16 V with timing chain</i>
Potenza max all'albero <i>Maximum output at crankshaft</i>	80,8 kW/110 hp a 4000/4400 giri/min. <i>80,8 kW/110 hp at 4000/4400 rpm</i>
Coppia max <i>Maximum torque</i>	230 Nm a 2600 giri/min. <i>230 Nm at 2600 rpm</i>
Cilindrata totale <i>Displacement</i>	1.248 c.c. <i>1.248 c.c.</i>
Alesaggio per corsa <i>Bore x stroke</i>	69,6 x 82 mm <i>69,6 x 82 mm</i>
Cilindri <i>Cylinders</i>	4, in linea <i>4, in line</i>
Sistema di iniezione <i>Injection system</i>	Iniezione diretta Common rail <i>Direct injection Common rail</i>
Aspirazione <i>Aspiration</i>	Sovralimentato con turbocompressore a geometria variabile <i>Supercharged with variable geometry turbo</i>
Sistema di avviamento <i>Starting system</i>	Motorino di avviamento elettrico 12 V - 1,3 kW <i>Electric starting 12 V - 1,3 kW</i>
Alternatore standard <i>Alternator</i>	14 V - 75 A <i>14 V - 75 A</i>
Sistema di raffreddamento <i>Cooling system</i>	Doppio circuito con scambiatore di calore <i>Double water cooling system with heat exchanger</i>
Sistema di lubrificazione <i>Lubrication system</i>	Forzata con pompa ad ingranaggi <i>Forced lubricating system with pump</i>
Max inclinazione di montaggio <i>Max. mounting inclination</i>	10° <i>10°</i>
Peso a secco senza invertitore <i>Dry weight without gear</i>	178 kg <i>178 kg</i>
Supporti motore <i>Engine mounting</i>	Supporti elastici anti-vibranti <i>Rubber type anti-vibration mounting</i>
Certificazione <i>Environmental</i>	RCD 2003/44/CE ed EPA TIER 3 <i>RCD 2003/44/CE and EPA TIER 3</i>

POTENZE SECONDO ISO 8665, COMBUSTIBILE DIESEL EN 590, TOLLERANZA SULLA POTENZA 5%
POWER ACCORDING ISO 8665, TOLERANCE 5%, DIESEL FUEL ACCORDING EN 590

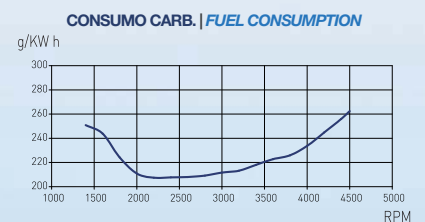
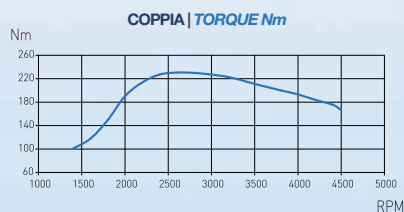
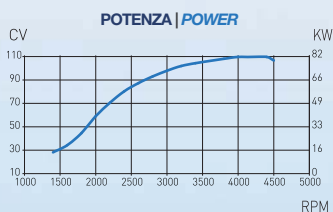

DIMENSIONI MOTORE | ENGINE DIMENSIONS

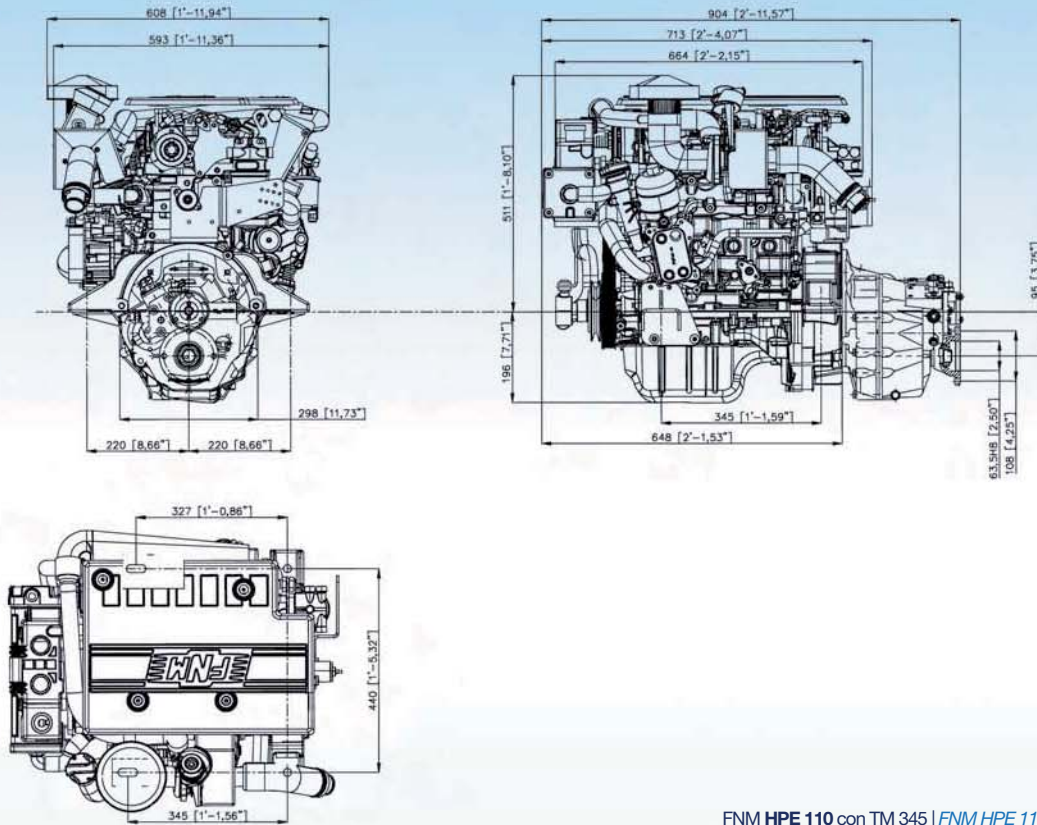

FNM HPE 110 con TM 345 | FNM HPE 110 with TM 345 gearbox

QUADRO STRUMENTAZIONE | INSTRUMENT PANEL

- Quadro assemblato CANBUS con Contagiri (5 pollici), spie allarme e blocco chiave
| *CANBUS assembled panel with Tachometer (5"), alarm lights and key block*
- Display multifunzione con visualizzazione di: Temperatura motore, Pressione olio, Tensione Batteria, Pressione Boost, Carburante
| *Multifunction display with info about: Engine temperature, Oil pressure, Voltage, Boost Pressure, Fuel*
- Strumenti aggiuntivi disponibili: Multifunzione (5 pollici), Velocità (5 pollici), Strumenti singoli (2 pollici)
| *Additional instruments available: Multifunction (5"), Speedometer (5") Single gauges (2")*
- Standard CANBUS J1939 espandibile a NMEA2000
| *CANBUS Standard J1939 upgradable to NMEA2000*



ACCESSORI DOTAZIONI STANDARD | ACCESSORIES STANDARD PACKAGE

- Invertitore idraulico | *Hydraulic gearbox*
- Supporti elastici | *Set of flexible mounts*
- Alternatore auto regolato 14 V - 75 A
| *Alternator 14 V - 75 A with built-in regulator*
- Motorino avviamento 12 V - 1,3 kW | *Starter motor 12 V - 1.3 kW*
- Filtri olio e combustibile | *Oil and fuel filters*
- Gomito scarico inox refrigerato
| *Stainless steel seawater-cooled elbow*
- Filtri Racor | *Racor filters*
- Quadro strumentazione con 8 mt. cablaggio
| *Instrument panel with 8 mt. cable*
- Pompa acqua mare in bronzo | *Bronze seawater pump*
- Cover motore | *Engine top cover*
- Collettore scarico refrigerato | *Water-cooled exhaust manifold*
- Puleggia anteriore con gola libera ISO 4183 profilo SPB
| *1-groove front pulley ISO 4183 type SPB*

OPTIONAL | OPTIONAL

- Kit tubazioni per riscaldamento interno imbarcazione
| *Kit for boat internal heating*
- Cablaggio ausiliario 2 mt. | *2 mt. auxiliary extension cable*
- Quadro flybridge con 8 mt. cablaggio
| *Flybridge instrument panel with 8 mt. cable*
- Trolling valve | *Trolling valve*
- Puleggia anteriore a due gole libere | *2-groove front pulley*
- Sistema di propulsione ibrido FNM HS
| *Hybrid propulsion system FNM HS*
- Connessione NMEA2000 per GPS
| *GPS NMEA2000 standard connection*



Authorized Dealer:
BAYSAN MARINE
Tel. +90 212 485 17 14 (pbx)
Info@baysanmarine.com



N° 1294605/05/S



N° EMS-224/S



N° TS/12946/05